

LEVEL GAUGE-LGM

FEATURES

- 3 SIZES ARE AVAILABLE 3",5" &10" BETWEEN BOLT CENTER.
- THE UNIT IS SUPPLIED WITH WASHER AND O-RING TYPE CONSTRUCTION.
- SUITABLE FOR MINERAL AND PETROLEUM-BASED OILS.
- CAN BE MOUNTED ON TAPPED HOLES.
- THE TEMPERATURE SCALE IS BETWEEN 20°C TO 80°C, MAXIMUM WORKING TEMPERATURE 80°C
- SUITABLE FOR NON-PRESSURIZED TANKS ONLY.

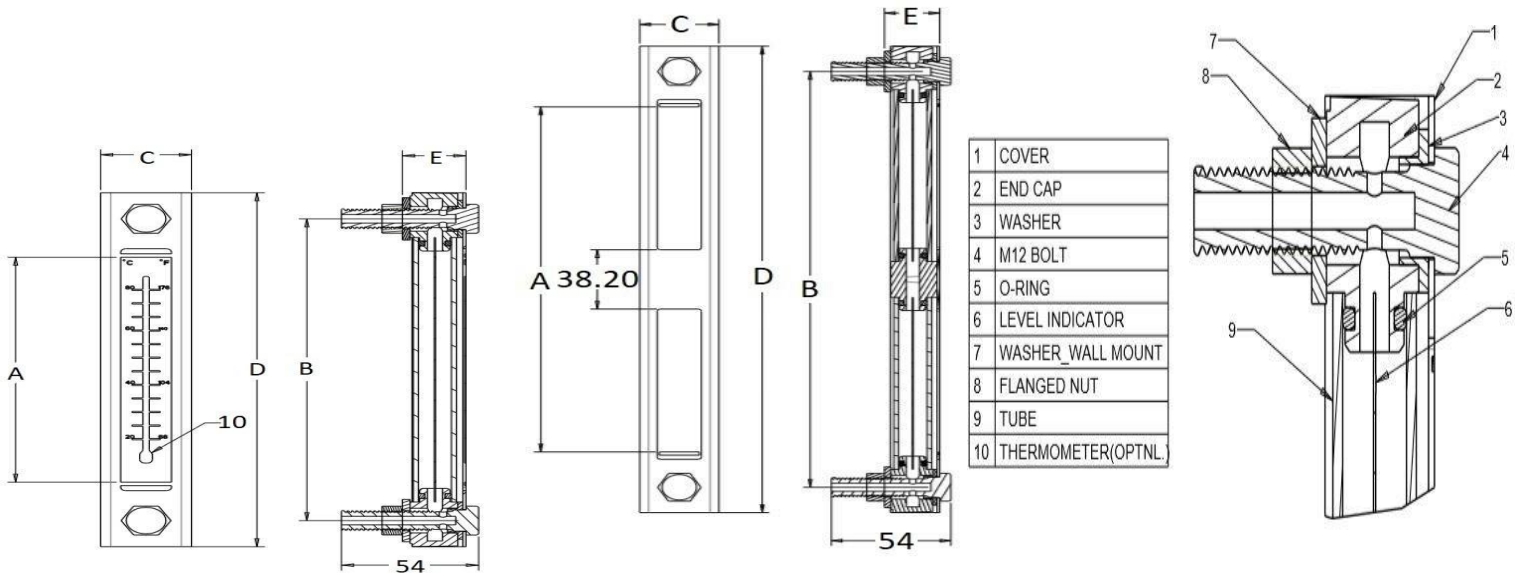

LGM-03, 05"

LGM-10"

MODEL	A	B	C	D	E	BOLT THREAD	WEIGHT IN KG
LGM-03	28	76	35.60	107	25	M12	0.23
LGM-05	76	127	35.60	157.80	25	M12	0.28
LGM-10	203	254	35.60	285	25	M12	0.40

MODEL CODE: ASSEMBLY

LGM	-03	_*_*
SERIES	SIZE (INCH)	FEATURE-1
LGM-STEEL BODY	03 - 3"	T-THERMOMETER (OPTIONAL)
	05 - 5"	
	10 - 10"	

NOTE: DIMENSIONS IN MM FOR REFERENCE ONLY.